



Customize your water treatment equipment for improved return on investment

To operate your facility at improved levels of efficiency and achieve accelerated ROI, customize your water treatment system with Culligan exclusive accessories:

- Brine Reclaim
- Aqua Sensor®,
- Progressive Flow.

Culligan exclusive accessories are part of Culligan Matrix Solutions™ that combine durable and efficient equipment, systems experience, and technical experts who understand your unique requirements. From planning your system to installing your water treatment equipment, Culligan Matrix Solutions offer options that help deliver the quality of water to meet your needs.

EXAMPLES OF MARKETS SERVED:

CLINICS
 EDUCATIONAL FACILITIES
 ENERGY & POWER
 FOOD & BEVERAGE PRODUCTION
 FOOD SERVICE/RESTAURANTS
 GROCERY
 HEALTHCARE/HOSPITALS/BIO-PHARMACEUTICAL
 HOSPITALITY/LODGING
 MANUFACTURING
 MUNICIPAL DRINKING WATER
 OIL & GAS

Culligan Matrix Solutions Advantages:

- Simple System Integration
- Global Product Platform
- Flexible Configurations
- Quick Delivery/Easy Installation
- Exclusive Culligan Advanced Electronics
 - Historical Operating Data
 - Alarm Recognitions
 - US Standard and Metric Readings
 - Wireless Remote Monitoring Options
 - Telemetry Options



Pre-Treatment
Solutions



Membrane
Solutions



Deionization
Solutions



Storage
Solutions



Distribution
Solutions

Culligan Brine Reclaim

How it Works:

Culligan's Brine Reclaim technology returns a portion of reusable brine to the brine tank during a softener regeneration. During a typical softener regeneration brine is directed from the salt tank to the softener and then to drain. During the first part of the brine cycle the brine is laden with "hardness". During the later part of the regeneration cycle the "hardness" laden brine is replaced with "soft or sweet brine". With Brine Reclaim the "sweet brine" is diverted back to the salt tank to be used in the next regeneration cycle. The amount of brine directed to the brine tank is directly proportional to amount of salt saved.

Benefits

This solution enables your softener and your entire water treatment system to operate at improved efficiency.

Brine Reclaim can provide the following benefits:

- Reduced salt usage up to 25%
- Reduced water usage
- Reduced sewage costs as a result of reduced discharge to drain
- Reduced labor costs (salt loading costs)
- Increased Efficiency
- Improved return on investment (ROI)

Brine Reclaim can be retrofitted to improve your existing water softener, or can complete your end-to-end Matrix Solutions system.

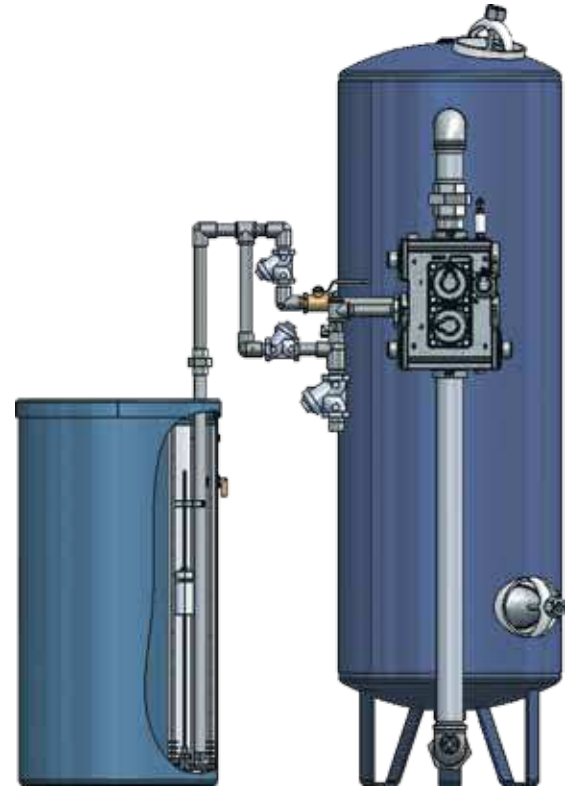

Typical Brine Curve for a Softener

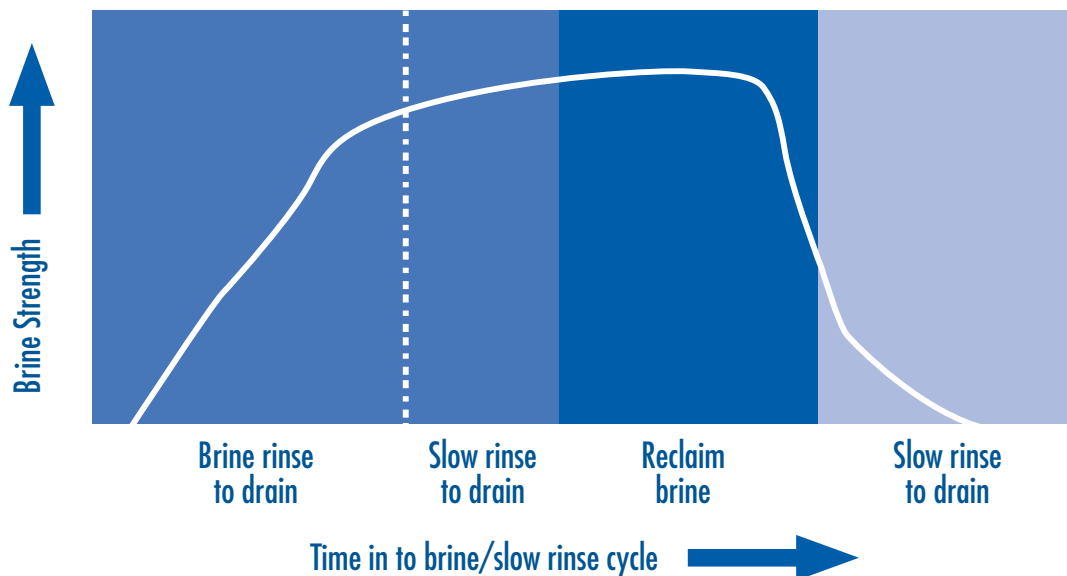

Culligan Aqua Sensor

How it Works:

With Culligan Aqua Sensor technology, an internal probe monitors the conductivity of the softener resin bed. Based on the measurements, it signals the need for regeneration when the softener is nearing exhaustion. The Aqua Sensor also monitors conductivity of the resin bed during the regeneration cycle. As a result, it controls the duration of the brine cycle.

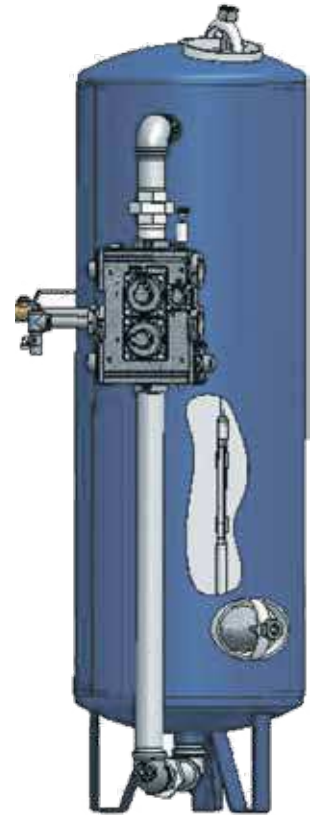

Benefits

Most softeners regenerate based on time or water flow, wasting salt and water. The Aqua Sensor adjust for influent water conditions (water quality, pressure, flow rate, temperature etc.) and provides for a more efficient softener operation.

Aqua Sensor provides the following benefits:

- Significant salt savings
- Significant water savings
- Reduced operating costs
- Improved return on investment (ROI).

Typical Aqua Sensor Measurements during a Service Cycle

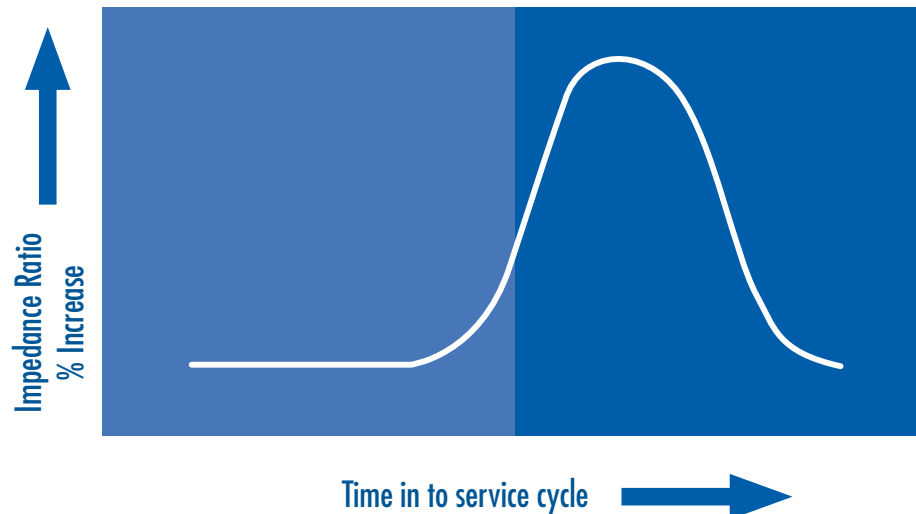

Culligan Progressive Flow

How it Works:

The Culligan Progressive Flow feature allows for one or more tank in a multiple tank softener or filter system to either be online or offline based on downstream flow demand. The Culligan Smart Controller monitors water demand and brings additional tanks online or offline as the flow demand changes. The feature is best suited for applications requiring intermittent/periodic high flow rates.



Benefits

Culligan designs your unique system based on your specific requirements—feed water, production and installation needs. With Progressive Flow, Culligan Matrix Solutions efficiency and cost savings are built into every water treatment system.

Progressive Flow provides the following benefits:

- Yields higher water flow rates using smaller tanks
- Improved efficiency
- Reduced initial capital costs
- Reduced operating costs
- Efficient use of space

Finally, an end-to-end solution from a single source.



Place your industrial and commercial water treatment needs in the hands of a global leader.

For over 75 years, Culligan has made better water. Our global network, comprised of 800+ dealers and international licensees in over 90 countries, is dedicated to addressing your water-related problems. As a worldwide leader in water treatment, our sales representatives and service technicians are familiar with the local water conditions in your area. Being global and local position us to deliver customized solutions to commercial and industrial water issues that affect your business and your bottom line.

www.culliganmatrixsolutions.com • 866-787-4293

Part No. # 47202 Print 06/12 ©2012 Culligan International Company.

All trademarks used herein are registered trademarks of Culligan International Company.
Products manufactured or marketed by Culligan and its affiliates are protected by patents issued or pending in the United States and other countries.
Culligan reserves the right to change the specifications referred to in this literature at any time, without prior notice.



Printed on recycled paper